

# AE5501, 5511

## TrafficTester Series



A hand-held measuring instrument for network installation testing.  
A single unit can test Ethernet networks at 10 Mbit/s, 100 Mbit/s, and 1 Gbit/s.



A traffic tester supporting multiple-port, full-wire speed testing.  
Equipped with BERT (Bit Error Rate Test) functions.



### Major features

- Performance testing at full-wire rates of 10 Mbit/s, 100 Mbit/s, and 1 Gbit/s
- Setting errors can be minimized through preset measurement conditions, greatly improving operation efficiency.
- Telnet-based remote control
- Testing networks including routers (Layer 3 line compatible)
- Reducing operator workloads by creating macros containing measurement conditions
- Achieving high-quality Ethernet measurement

### Example of installation testing procedures

■ This hand-held instrument for Ethernet installation and maintenance can handle 10 Mbit/s, 100 Mbit/s, and 1 Gbit/s networks with a single unit, implementing quick and easy measurement.

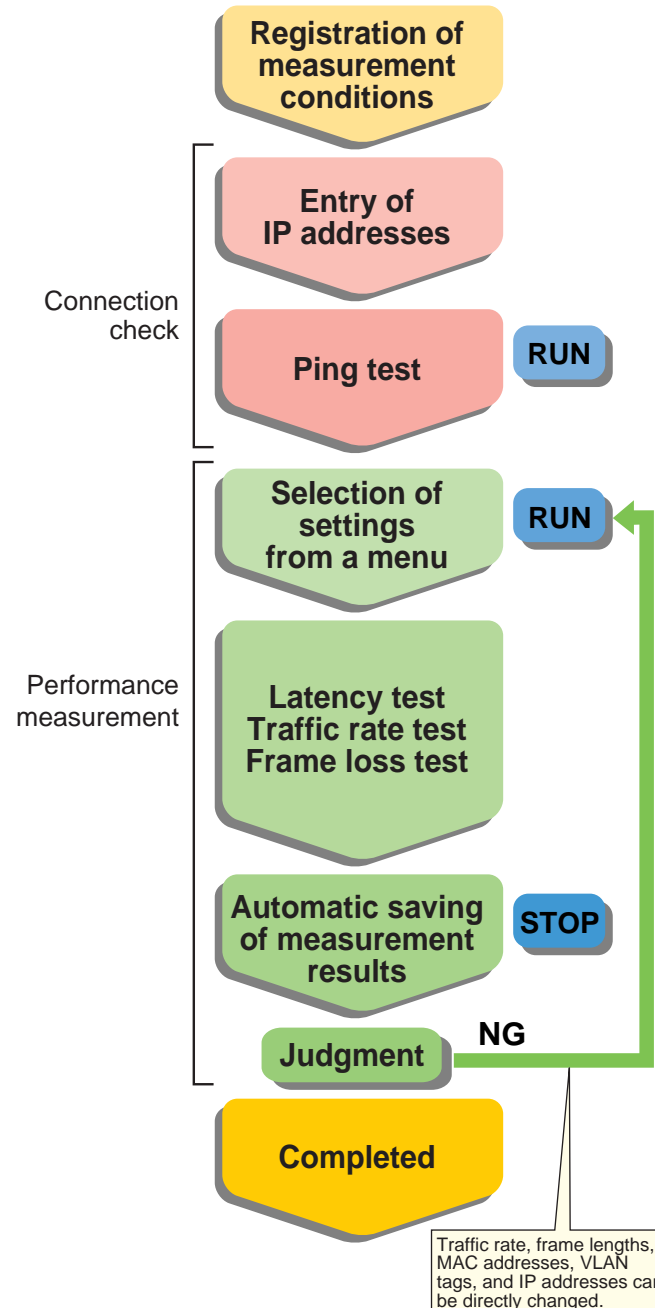

### Measurement condition setting and results output

#### ■ AE5730 Setup Software

Easy setting of test conditions on a personal computer

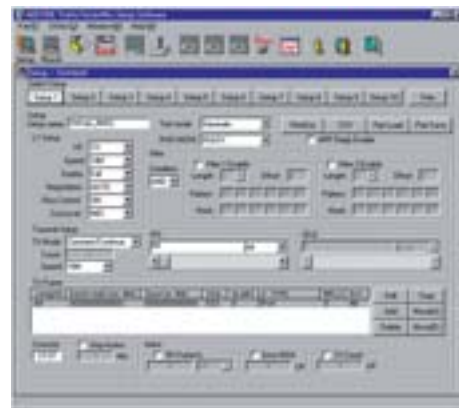

Viewing results files

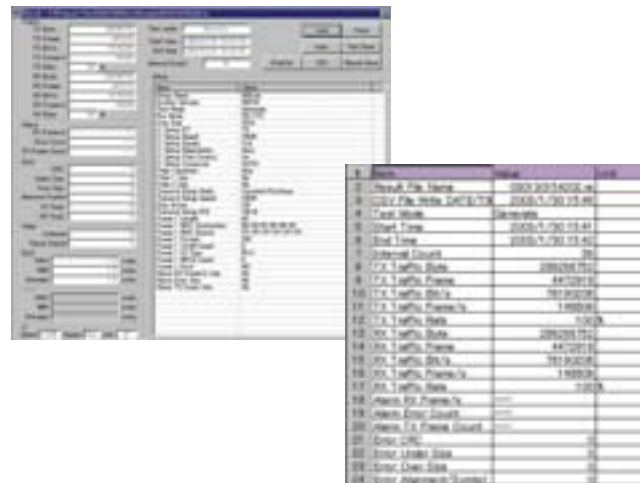

Converting results files in CSV format with a single click

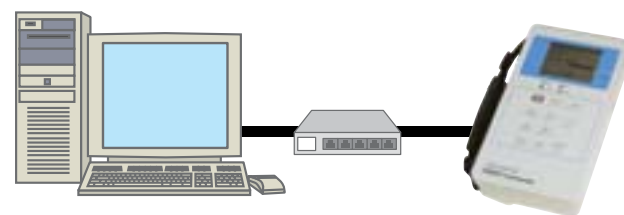

Up to 100 measurement results files can be automatically saved. These files can be transferred to a personal computer, so as to be easily managed and compiled as well as to be attached to e-mail for information exchange.

### Application 1

- Not only Layer 2 but also Layer 3 lines can be tested for connection and maintained. Tests that can be conducted include: Ping, traffic rate, latency, and frame loss tests.
- Line installation and maintenance between stations. Tests that can be conducted include: Ping, traffic rate, latency, and frame loss tests. As the AE5501 is a simple Ethernet traffic generator, it can be used in a variety of applications.
- Remote installation and maintenance facilitated through Telnet
- Network environments using dynamic IP addresses also supported, including DHCP function

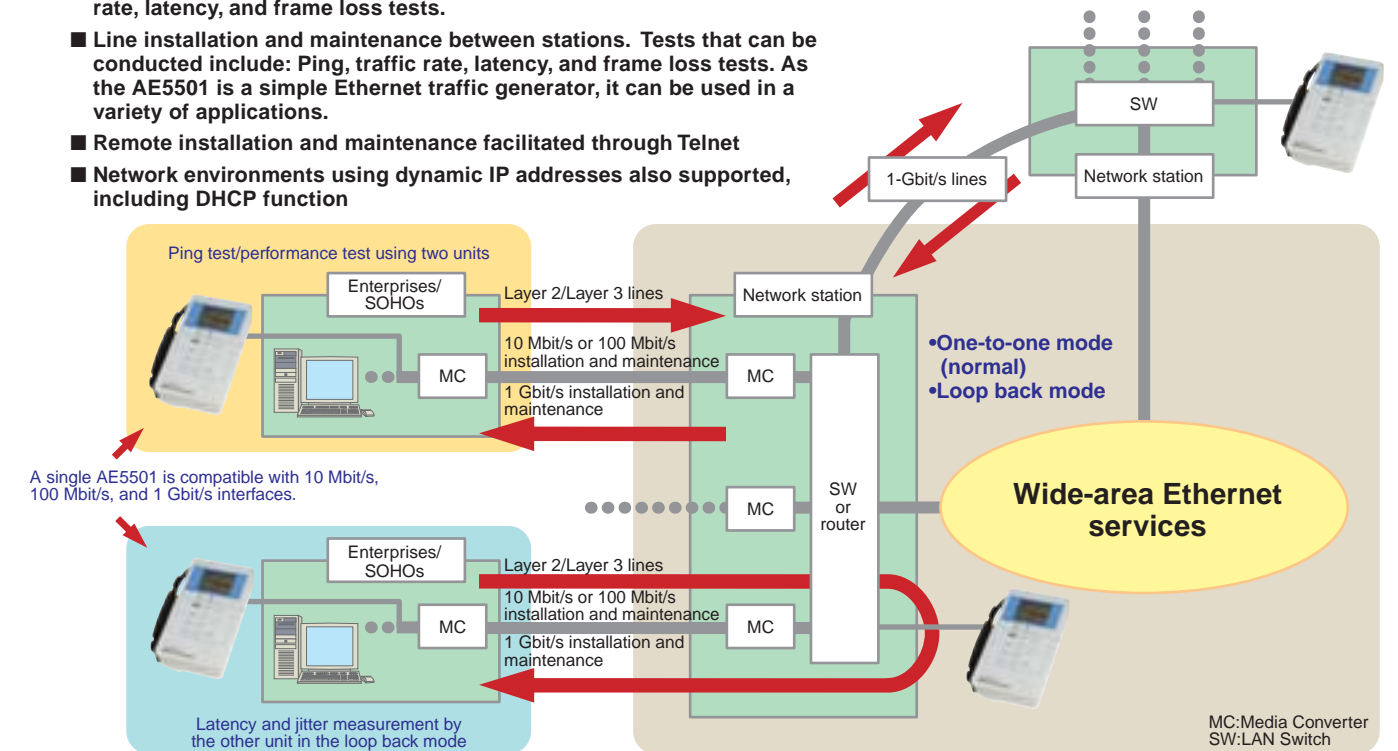

### Application 2

- Expediting testing work on the engineer side. More than one unit can be remotely controlled from a single personal computer through Telnet.

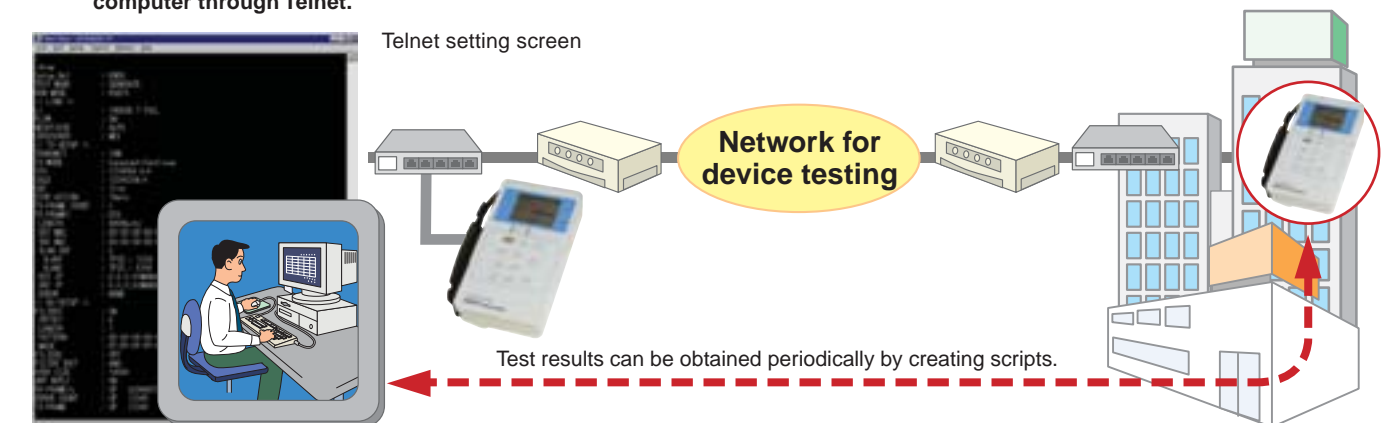

- CATV-based Internet access installation and maintenance through DHCP and ARP protocol support through Telnet. Latency and frame loss can be measured from a small amount of traffic flowing over the working lines.

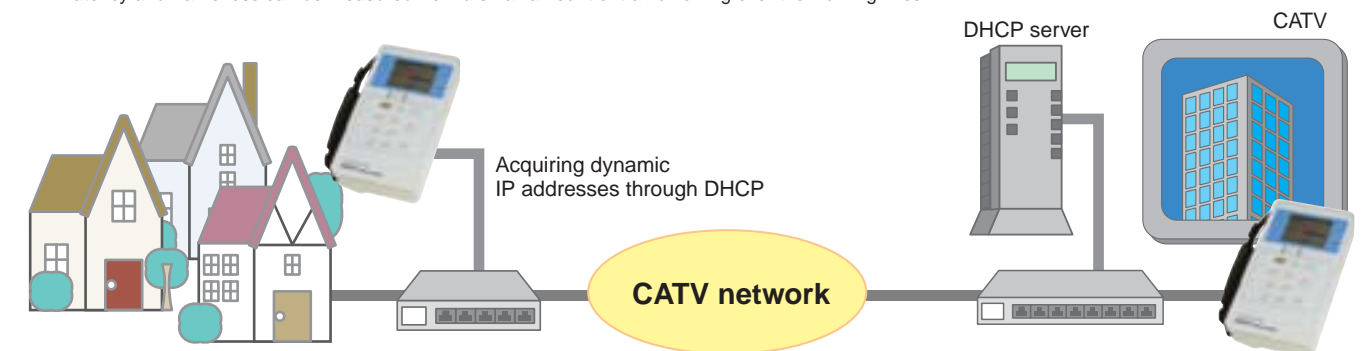

## Specifications

### Main unit

Interface specifications		
Measurement port standards	10BASE-T, 100BASE-TX, 1000BASE-T (RJ45), and 1000BASE-SX/LX (through a GBIC module)	
Line speed	10 Mbit/s, 100 Mbit/s, and 1 Gbit/s	
Remote port	10BASE-T (for uploading test conditions from and downloading measurement results to a PC)	
Telnet connection	Changing of condition settings, starting/stopping of measurement, and checking of ongoing measurement statuses are possible using a remote port.	
Duplex modes	10 Mbit/s and 100 Mbit/s: full-duplex/half-duplex; 1 Gbit/s: half-duplex only	
Cable connection	MDI and MDIX ports, automatic detection	
Negotiation	Automatic/manual	
Flow control	On/off (valid in the traffic generation mode only)	
Condition settings		
Traffic generation mode/latency measurement mode	Number of settings	Up to 10 settings can be registered.
Run setup	Number of transmission frames	Up to 4 for each setting
Stop action	Timing of transmission and reception	Transmission and reception can start simultaneously, or can be individually timed with the RUN button.
	Measurement period timer	On/off, can be set in minutes.
Line performance measurement		
Traffic generation mode (Traffic Generate Mode)		
Transmission	Transmission method	Flat transmission, basic burst transmission (4 frames), and count transmission
	IFG (Inter-frame gaps) rate measurement	From less than 1% to 110%
Frame setting	Transmitted patterns	Up to 4 frames can be set.
	Packet length	Packet length (26 to 9999 bytes), MAC header, VLAN tag (up to 4 stacks), LLC header, SNAP header, MPLS header (up to 4 stacks of SHIM headers), IPv4 header, IPv4 multicast, IPv6 header, and payload (up to 256 bytes)
	Error frame setting	CRC, oversize, undersize, CRC and oversize, and CRC and undersize
	Traffic counter	Tx/Rx rate (%), Tx/Rx frames/s, Tx/Rx bit/s, Tx/Rx frame count, and Tx/Rx byte count
Statistics functions	Error frame counter	CRC, oversize, undersize, and alignment
	Idle time measurement	Gaps between Rx frames with resolutions of 1 μs (10 Mbit/s) and 100 ns (100 Mbit/s and 1 Gbit/s)
	Others	Number of collisions (for half-duplex mode) and pause frames
Receive functions	Filter	Two sets of 48 bit (6 byte) patterns with an offset (0 to 58)
	Oversize frame setting	From 65 to 10,000 bytes
	ARP reply	On/off
	Alarms	Thresholds for number of Rx frames/s, number of Tx frames, and total error count
Latency measurement mode (Latency Mode)		
Latency	Maximum, minimum, and average; Resolution: 1 μs for 10 Mbit/s and 100 ns for 100 Mbit/s and 1 Gbit/s; Maximum error: 3 μs for 10 Mbit/s and 300 ns for 100 Mbit/s and 1 Gbit/s	
Ping test and traffic loop back function		
Ping test mode		
Transmission	Source MAC address	Manual setting, global MAC address, and setting upon acquisition of a dynamic IP address (through DHCP)
	Source IP address	Manual setting and dynamic IP address
	Transmission frame	Programmable frame lengths (From 64 to 1518 bytes)
	Transmission intervals	1, 5, and 10 seconds
	Transmission modes	Normal transmission, and frame count transmission
	VLAN tags	Up to 4 stacks
Display (main unit's LCD only)	Displays destination's MAC address after resolving ARP requests.	
Ping reply mode (Reply Mode)		
Transmission	Source MAC address	Manual setting, global MAC address, and setting upon acquisition of a dynamic IP address (through DHCP)
	Source IP address	Manual setting and dynamic IP address (through DHCP)
	VLAN tags	The number of VLAN stacks for transmitted frames can be set. The maximum number is 4.
Loop back mode		
Function	Swaps received frame's destination address (DA) with its source address (SA), re-calculates the CRC value, then replies to the frame.	
MAC addresses only	Source MAC address	Manual setting, global MAC address, setting upon acquisition of a dynamic IP address (through DHCP), and all of the aforementioned
Both MAC and IP addresses	Source MAC address	Manual setting, global MAC address, setting upon acquisition of a dynamic IP address (through DHCP), and all of the aforementioned
	Source IP address	Manual setting and dynamic IP address (through DHCP)
	VLAN tags	The number of VLAN stacks for transmitted frames can be set. The maximum number is 4.
ARP reply	On/off	
Measurement results file viewer (File View)		
New files	Displays the latest measurement results.	
Results files for each setting	Up to 100 files can be selected and displayed.	
File deletion	Can delete individual files, or all files.	
Dynamic IP address acquisition and ARP resolution (through DHCP)		
Dynamic IP address acquisition	Source MAC address	Manual setting and global MAC address
	Source IP address	Dynamic IP address (automatic) and manual setting (used to set ARP setting when the DHCP server is not available.)
ARP resolution	Destination IP address	Manual setting
Macro creation for continuous testing		
Ten preset test settings (up to 50 command lines) can be successively put into effect.		
Remote setting		
Modes	Remote	Measurement condition setting and results file transfer (through DHCP or manual operation)
	Upgrade	Upgrades the AE5501 main unit (through DHCP or manual operation).
	Telnet	Remote control through Telnet. The command prompt and password can be set (through DHCP or manual operation).
Default settings (ALL DEFAULT)		
Initializes the AE5501 settings.		
Hardware specifications		
Display	Monitor	2.8-inch LCD (320 × 240 dots, dot-matrix display)
	Adjustable contrast	
Power supply	Input interface	Original key pad
	AC supply	Adapter at 100 to 240 V and 50 to 60 Hz, with 18-VA output
Dimensions and weight	Battery	Rechargeable 6 NiMH batteries (Can operate over 1.5 to 2 hours depending on the interface.)
		Approximately 120 (W) × 60 (H) × 215 (D) mm and 1.2 kg (including battery)
Accessories	Standard	CD-ROM (AE5730 Setup Software), AC adapter, power cable, and user's manuals
	Optional	Six rechargeable 1.2-V NiMH batteries, battery charger, soft carrying case, 1000BASE-LX GBIC module, and 1000BASE-SX GBIC module

\* Note that only the GBIC modules from Yokogawa are guaranteed.

## Main Features

- 10Mbit/s-10Gbit/s Ethernet Testing Capabilities
- Up to 32 ports per frame (10/100BASE-TX)
- Full-wire rate traffic generation and statistics monitoring
- Frame BERT(Bit Error Rate Test) function
- Frame latency and inter-frame gap measurement
- Capture capability\*
- Multi-user function for up to 8 users

\* Depends on unit



## Overview

AE5511 TrafficTesterPro is an IP traffic generation tester that provide test solutions to evaluates and inspects network equipment such as LAN switches, routers and GE-PON. TrafficTesterPro offers flexible modular design. Customers can choose and exchange units to support their specific needs or to adapt to new interfaces and standards. Yokogawa is offering a wide variety of units, from highly functional type units, which have all the necessary functions to develop and inspect IP network equipment to affordable units, which provide cost-cutting at production and during shipping inspections.



An examples of the control software display

## Unit Overview

Module	Interface	Number of Ports
AE5520 10/100BASE-T unit	10BASE-T, 100BASE-TX	16 ports
AE5521 1000BASE-X unit	1000BASE-SX, 1000BASE-LX	4 ports (GBIC)
AE5522 10GBASE-X unit	10GBASE-LR, 10GBASE-ER, 10GBASE-SR	2 ports (XENPAK)
AE5523 1000BASE-T unit	10BASE-T, 100BASE-TX, 1000BASE-T	12 ports
	1000BASE-SX/LX	1 port (SFP)
AE5524 1000BASE-X unit	1000BASE-SX, 1000BASE-LX	12 ports (SFP)

## List of Functions by Unit

	AE5520	AE5521	AE5522	AE5523	AE5524
Full-wire rate traffic generation function	●	●	●	●	●
Latency measurement function	●	●	●	●	●
Frame BERT function	●	●	●	●	●
Capture function	—	—	●	●	●
Multi user function	▲*1	▲*1	▲*1	●	●
Link down generation function	▲*2	▲*2	▲*2	●	●
IPv4 emulation function	●	●	●	●	●
IPv6 emulation function	—	—	—	●	●
Sequence check function	—	—	—	●	●
Alarm log function	—	—	—	●	●
Statistics monitoring function per QoS	—	—	—	●	●
PoE measurement function	—	—	—	●	—
Clock variable function	—	—	—	●	●
LFS function	—	—	●	—	—

\*1: Can share per unit

\*2: Only for single link down generation



## Latency Measurement Function

Latency measurement calculates the transmission time within the network instruments by applying load to the instruments. The packet can be tested in a similar network environment as it is possible to combine IPv4, IPv6 and such.

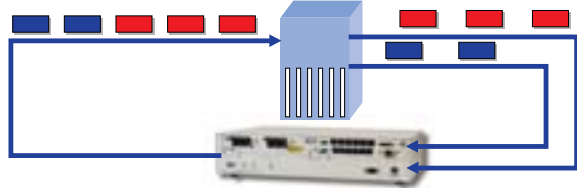

### Examples of measurement s of latency time and gaps between frames.

	UNIT1-PORT01	UNIT1-PORT02
[Latency]Max IFG(us)	0.1	0.1
[Latency]Min IFG(us)	0.0	0.0
[Latency]Avg IFG(us)	0.1	0.1
[Latency]Max Packet Latency(us)	0.2	0.2
[Latency]Min Packet Latency(us)	0.1	0.1
[Latency]Avg Packet Latency(us)	0.1	0.1

## BERT Frame Function

BERT(Bit Error Rate Test) Frame Function detects the bit error in the transmission instrument by inserting pseudo-random patterns (PN15) into the payload of the Ethernet frame.

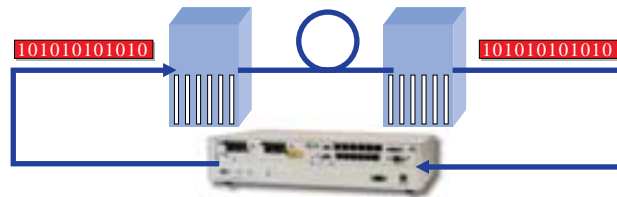

## Capture Function

The capture function is effective when investigating the cause of errors occurring during development and verification of network equipment. Users can unerringly import data using filters and trigger functions when errors occur. Furthermore, upper level protocols with commercially available software can be analyzed as it can be stored in CSV and PCAP formats.

### Trigger Setting

Trigger setting can capture error frames and sequence errors in triggers. Is effective when analyzing infrequent interferences.



## Packet Latency Measurement per Flow

Customers can test Quality of Service (QoS) functions, which transmits vital priority data in real time such as Voice over IP (VoIP) and moving images. The AE5511 can display the latency times of packets, which were filtered by IP type of service (TOS ) values and LAN Priority, of up to 8 channels per flow.

	UNIT1-PORT01	UNIT1-PORT02
[Latency]Max IFG(us)	0.1	0.1
[Latency]Min IFG(us)	0.0	0.0
[Latency]Avg IFG(us)	0.1	0.1
[Latency]Max Packet Latency(us)	0.2	0.2
[Latency]Min Packet Latency(us)	0.1	0.1
[Latency]Avg Packet Latency(us)	0.1	0.1
[OH1]Max Packet Latency(us)	0.2	0.2
[OH1]Min Packet Latency(us)	0.1	0.1
[OH1]Avg Packet Latency(us)	0.1	0.1
[OH2]Max Packet Latency(us)	0.2	0.2
[OH2]Min Packet Latency(us)	0.1	0.1
[OH2]Avg Packet Latency(us)	0.1	0.1
[OH3]Max Packet Latency(us)	0.2	0.2
[OH3]Min Packet Latency(us)	0.1	0.1
[OH3]Avg Packet Latency(us)	0.1	0.1
[OH4]Max Packet Latency(us)	0.2	0.2
[OH4]Min Packet Latency(us)	0.1	0.1
[OH4]Avg Packet Latency(us)	0.1	0.1

### Example of BERT Measurement

Can detect whether the transmission instrument corrected the frame error or not as both frame and bit errors can be displayed at the same time.

	UNIT1-PORT01	UNIT1-PORT02
[BERT]Bit Error Rate (E-32)	0.0	0.0
[BERT]Bit Error Count	0	0
[BERT]Bit Error Frame	0	0
[BERT]Bit Error Loss	0	0
[BERT]BERT Checked Byte	178,666,566	178,666,566
[BERT]Bit Error Data	0	0
[BERT]Bit Error Frame(Frame)	0	0
[BERT]Bit Error Loss Frame	0	0
[BERT]BERT Checked Bytes	38,690,470	38,690,470
[BERT]Bit Error Insert	0	0
[BERT]Bit Error Insert Frame	0	0



### Filter Setting

Can capture specific frames with this filter setting and can easily analyze interference.



## Sequence Check Function

The sequence check function detects the number of packet loss, the reverse order of packets, and duplicate packets by cross-checking the sequence numbers entered into the frame. This function makes it easy to check the performances of LAN switches and routers. Furthermore, this function can easily analyze the causes of errors by setting the sequence error to capture trigger.

### Settings for Sequence Check

To activate the sequence check function, put a check before "enter sequence counter". It is also possible to activate the sequence check function in the insert frame.



## Alarm Log Function

The alarm log function can detect and record logs of packet errors (CRC errors, alignment errors, symbol errors, undersize, oversize, etc.) , abnormalities in Inter Frame Gap (IFG) (under 96 bits), variations in Layer1 (linkup, link down, etc.) , abnormalities in mail receiving rates, abnormal packet latencies, and sequence errors. Abnormalities in mail receiving rates and abnormal packet latencies can be detected by specifying the QoS channel which is effective in verifying priority control per flow and bandwidth control.

### Alarm Setting



## Automatic Address Acquisition

The automatic address acquisition function is a function that acquires MAC addresses of the device under test (DUT) form IP addresses. It is no longer necessary to carry out cumbersome tasks such as setting MAC addresses of the transmitting frame. This function improves work efficiency and prevents operation errors. In case of IPv6, it is possible to display the gateway MAC address obtained through the Router Advertisement (RA) requested by the Router Solicitation (RS) and can be used as the MAC address for the transmitting frame.

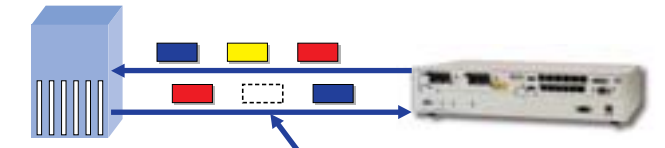

Detection of packet loss, etc.

### Display Results of Sequence Check



## Packet Error Detection



## Abnormal Packet Latency Detection



## Abnormal Detection in Mail Receiving Rate



### Examples of Alarm Log Displays



## Examples of Automatic Address Acquisition

Please refer to the list of MAC addresses acquired through this target IP addresses



## Link UP/DOWN Function

The link UP/DOWN function can generate pseudo-link DOWN conditions which can be used to make periodic swap evaluations of cables and verify operations during interference in transmission channels. It is also possible to detect and display the link DOWN on the statistical monitor.

### Example of Link UP/DOWN Settings



### Example of a Display of Link Down Detection



## Transmitting Clock Variables

AE5523 can vary the transmitting clock within the range of  $\pm 100$ ppm. This function can verify the malfunctions of the network equipment and margin due to clock variations before hand.

### Clock Adjustment

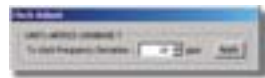

### Examples of Send/Receive Clock Frequency Deviation Measurements



## Automatic Negotiation

The automatic negotiation function can automatically differentiate the communication speed (10M/100M/1000M) between instruments and the communication modes (full duplex/half duplex communication) and can make optimum settings. Communication speed and modes, and the ON/OFF of flow control can be set manually as well.

### Setting for Automatic Negotiation



## Auto MDI/MDI-X Function

AE5520 and AE5523 has a built-in Auto MDI/MDI-X function which automatically detects the straight/cross type of the connected cable to avoid problems due to mistakes in wiring.

## Link Fault Signaling (LFS) Function

AE5522 supports the Link Fault Signaling (LFS) function, which notifies faults on a physical layer between 2 10 Gigabit Ethernet ports. It can display the number of transmitting/receiving and detections of Local Fault (LF) and Remote Fault (RF). It is effective in pursuing causes for physical faults as it can capture data by triggering LF and RF.

### Transmitting LF and RF



### Example of a Chart for the Number of LF/RF Detection



## PoE Function

AE5523 has a built-in Power Device (PD) for Power over Ethernet (PoE) emulation function, which can detect class declarations (class 0-4) and power feed conditions (ON/OFF). This function can test IP loads by connecting a pseudo-PoE terminal to the DUT. It is also possible to conduct electric tests by connecting the PoE monitor terminal to a voltmeter or electronic load equipment.

### PoE Class Setting



### Example of PoE Feed Display



## Network Setting

Network settings can optionally define MAC addresses and IP addresses on to the test port. Furthermore, it can make ARP/PING responses when testing IP equipment and IP networks such as Layer3 switches and routers. AE5523 also supports VLAN settings, IPv6 proximity search replies and PING6.

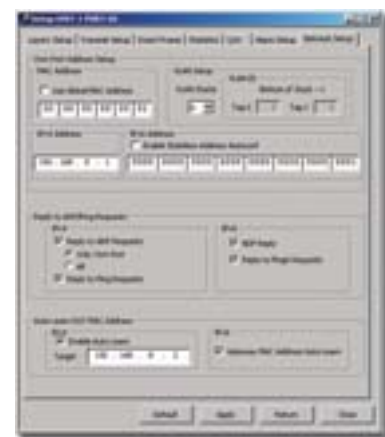

## Multi User Function

AE5511 supports multi-user function that can be shared with up to 8 persons using a dedicated Windows software. As AE5523 can share the available ports by multi users, it significantly reduces cost for customers.

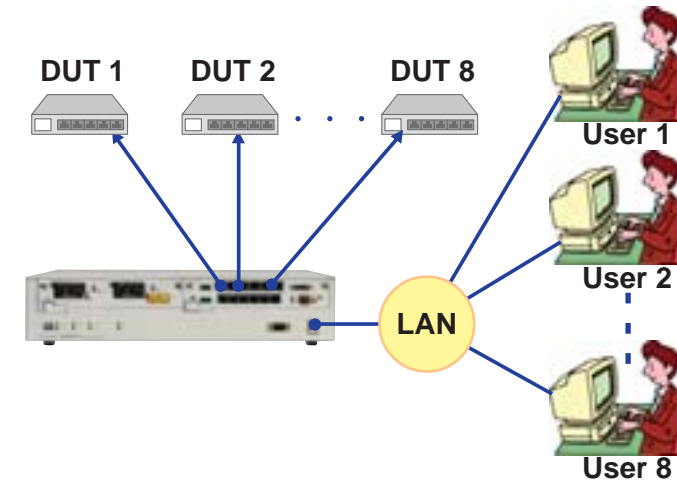

### Example of Log In Screen

User can register log in access names and IP addresses. Has password security control.



### Example of Port Reserve Screen.

User can reserve the test port when logging in. In addition the reserved port can be used consecutively by locking the port when logging out.



## Automatic Testing Function

AE5511 can be controlled remotely through Telnet. By defining multiple test conditions in script files and executing them, measurement can be performed automatically, reducing the time required for interim evaluation in the development phase as well as in pre-shipment inspection.

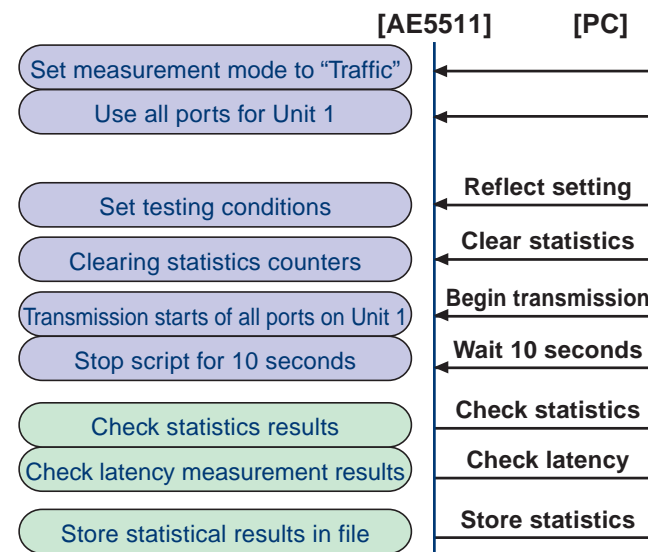

[Example of an Execution of Automatic Measurement]



```

#!filestart
$mode traffic
$u1_useport all
print'*****'
print'* Throughput test start *'
Print'*****'
# port configuration
poupdate frame64byte.fullwire.test.setup unit 1 port all

poststatistics clear unit 1 port all
#start transmit
porun start unit 1 port all
waittime 10

poshowcounter rx_rate unit 1 port all
print'*****'
print'* Latency test *'
print'*****'
poshowcounter rx_latency unit 1 port all
posaverresult result unit 1 port all
#!fileend
    
```

[Example of Script]

[Example of Storing Measurement Results]



## Specification

Item	Specification
Control port	10/100BASE-T(RJ-45) × 1
Console port	RS-232C(D-sub) × 1
LED display	POWER,STANDBY,HDD,REMOTE,STATUS,STATUS1,STATUS2,LINK
Power	AC90-264V,48-63Hz
Consumption electricity	200VA
Dimensions /Weight	Approx. 435 (W) × 88 (H) × 300 (D) mm Can be mounted on a 2U high 19 inch rack Approx. 7kg (AE5511 main unit only)
Unit packaging slot	2 slot
Operation Environment	Temperature range: 5°C-40°C Humidity range: 35°C-85°C
Standard accessories	User manual, start up manual, power cable, control port connection cable (1.5m long, cross over cable with RJ-45 connector), console port connection cable (1.5m long, RS-232C cross over cable), CD-ROM(AE5511 TTPro Control Window Application)

## System Requirements

Item	Specification
PC	PC/AT Compatibility
OS	Windows2000 SP3, SP4, WindowsXP SP1, SP2
CPU	PentiumIII 1.2GHz or faster
Memory	more 512MB
HardDisk	Space capacity more than 200MB(Recommendation more 300MB)
Disk device	CD-ROM drive

## Model/Specification Cords

### ■ AE5501 TrafficTesterMini

Product Name	Model Name	Code	Specification
AE5501 TrafficTesterMini	417322600	-A	Domestic standard
		-C	UL/CSA standard
		-E	VDE standard
		-G	SAA standard
		-S	BS standard
		-V	GB standard
		-LNJ	Japanese
		-LNE	English
AE5730E Setup Software	417322607		Note: Must order with main body

### ■ AE5511 TrafficTesterPro

Product Name	Model Name	Code	Specification
AE5511 TrafficTesterPro	417322900	-L	Domestic standard
		-C	UL/CSA standard
		-E	VDE standard
		-G	SAA standard
		-S	BS standard
		-V	GB standard
		-LNJ	Japanese
		-LNE	English
AE5520 10/100BASE-T Unit	417322901		
AE5521 1000BASE-X Unit	417322902		
AE5522 10GBASE-X Unit	417322904		
AE5523 1000BASE-T Unit	731010		
AE5524 1000BASE-X Unit	731011		

■ Trademarks Windows and Internet Explorer are registered trademarks or trademarks of Microsoft Corporation in the United States and other countries.  
Pentium is a registered trademark or trademark of Intel Corporation

(Notes) The contents of this document may be subject to change without prior notice with the improvements of the product performance and quality. These products may be under export control by the Japanese government as required by the Foreign Exchange and Foreign Trade Law.

# YOKOGAWA

**YOKOGAWA ELECTRIC CORPORATION**

Communication & Measurement Business Headquarters /Phone: (81)-422-52-6768, Fax: (81)-422-52-6624

E-mail: tm@csv.yokogawa.co.jp

**YOKOGAWA CORPORATION OF AMERICA**

Phone: (1)-301-916-0409, Fax: (1)-301-916-1498

**YOKOGAWA EUROPE B.V.**

Phone: (31)-33-4641858, Fax: (31)-33-4641859

**YOKOGAWA ENGINEERING ASIA PTE. LTD.**

Phone: (65)-62419933, Fax: (65)-62412606

Subject to change without notice.

[Ed : 02/b] Copyright ©2005

Printed in Japan, 508(KP)